

TND 140

Universal CNC Automatic Lathe



ergomat

■ 60° slant bed		TND 140
■ Working area		
Swing Ø over way covers	mm	440
Swing Ø over cross slide	mm	230
Turning diameter with standard tools	mm	180
Chuck diameter	mm	135/160
Collets	DIN	6343
X Axis travel	mm	125
Z Axis travel	mm	250
■ Main spindle		
Spindle Nose Ø	mm	140
Bar capacity Ø	mm	42
■ Spindle drive		
Spindle speed max.	rpm	5.000
Power 100% / 25%	kW	5,5/7,5
Torque 100% / 25%	Nm	42/70
■ Slide drives		
Rapid feed - X / Z axes	m/min	30
■ Turret		
Number of tool stations		12
Square shank	mm	16 x 16
Round shank Ø	mm	25
Tool holders - standard		Direct clamping
Tool holders - optional		VDI 25*
■ C axis		
Resolution	degrees	0,089
■ Live tools		
Number of live tools		12
Tool clamping system		VDI 25
Tool shaft Ø	mm	13
Power	kW	2,2
Torque	Nm	8
Live tool speed max.	rpm	5.000
■ Fully programmable hydraulic tail stock		
Morse tape center	mm	CM3
■ Cooling system		
Coolant pressure standard / optional	bar	4 / 20*
Tank capacity	l	135
■ CNC		
Fanuc		0i-TF
■ Dimensions		
Length x width x height	mm	2880 x 1440 x 1830
■ Weight	kg	3.600

Specifications are subject to change without notice

*Option

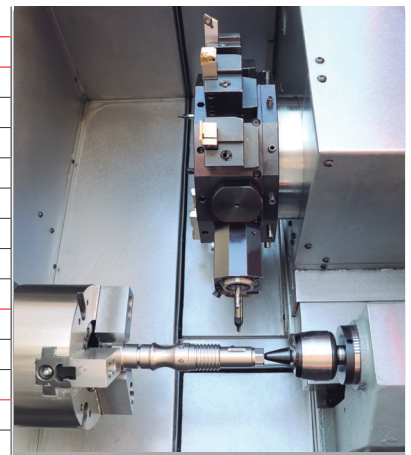

Three jaw-chuck and hydraulic driven tailstock

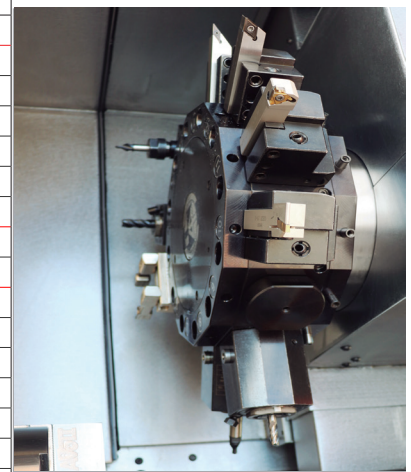

12 position turret for live tools

Options:

- Turret for live tools
- Fully programmable hydraulic tail stock
- High pressure cooling system 20 bar
- Depth stop device
- Power chuck
- Quick changing collet chuck
- Parts catcher
- Bar feeding magazines
- Tool holders for fixed and live tools

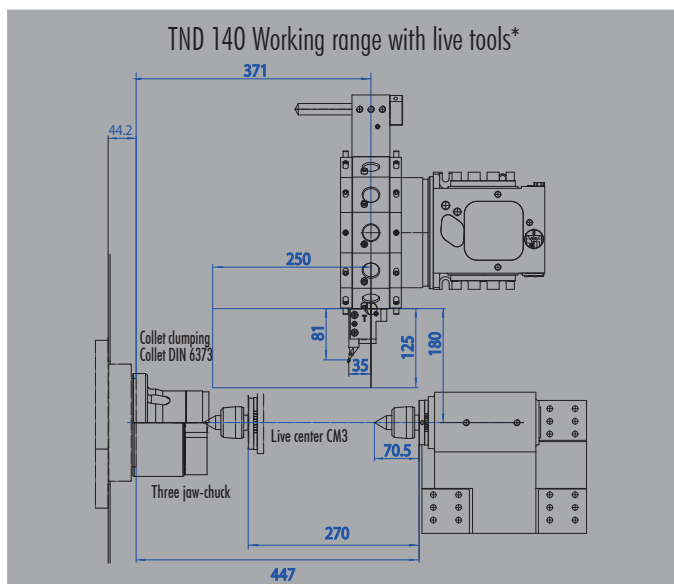

04/2019 - Ergomat

ergomat